

(No Model.)

L. LANDERKIN.

SLIDE REST.

No. 245,514.

Patented Aug. 9, 1881.

Fig. 1.

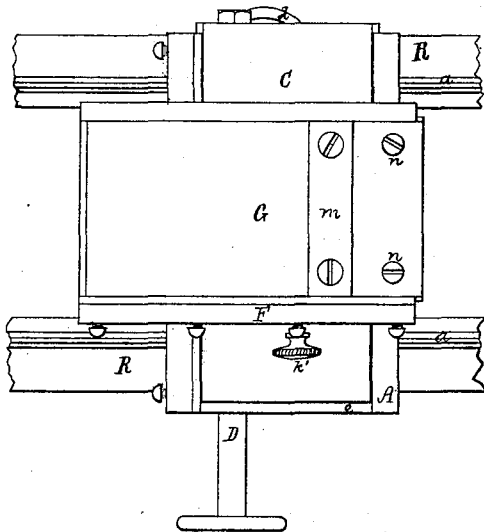

Fig. 4.

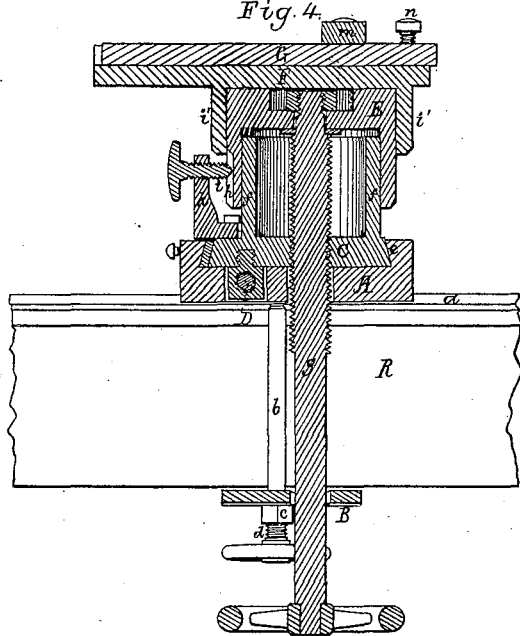

Fig. 2.

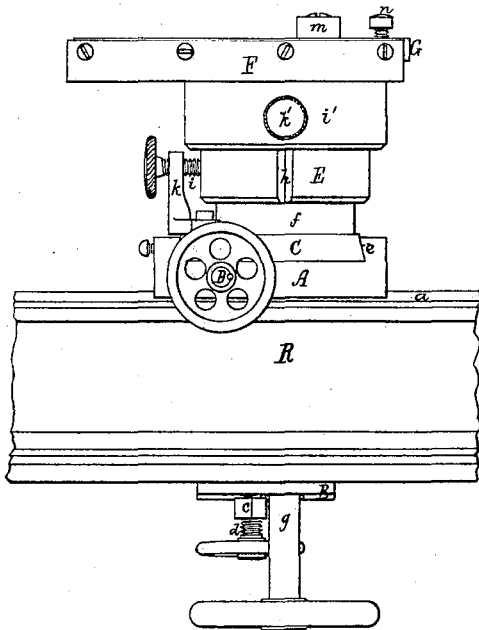
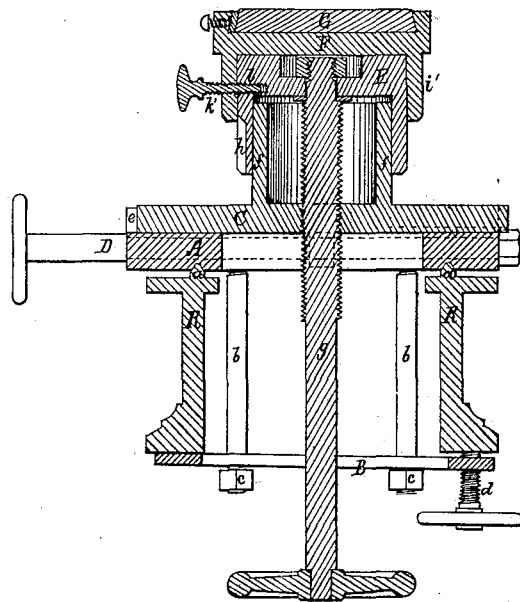

Fig. 3.



Witnesses
L. N. Piper
E. B. Smith

Inventor.
Hewellyn Landerkin.
R. U. Eddy

UNITED STATES PATENT OFFICE.

LLEWELLYN LANDERKIN, OF CAMBRIDGEPORT, MASSACHUSETTS.

SLIDE-REST.

SPECIFICATION forming part of Letters Patent No. 245,514, dated August 9, 1881.

Application filed June 4, 1881. (No model.)

To all whom it may concern:

Be it known that I, LLEWELLYN LANDERKIN, of Cambridgeport, of the county of Middlesex and State of Massachusetts, have invented a new and useful Improvement in Slide-Rests for Lathes; and I do hereby declare the same to be described in the following specification, and represented in the accompanying drawings, of which—

10 Figure 1 is a top view, Fig. 2 a front elevation, Fig. 3 a transverse section, and Fig. 4 a longitudinal section, of a slide-rest containing my invention and applied to the bed-rails of a lathe, the nature of such invention being defined by the claim hereinafter set forth.

15 In the drawings, the parallel ways of the bed-rails R R of the lathe-frame are shown at *a a*, there being placed upon such ways the bed A of the slide-rest, such bed being grooved to receive the said ways. From this bed two rods, *b b*, extend down between the rails R R, and to and through a slotted clamp-plate, B, which is supported beneath the said rails by such rods, and by nuts *c c* screwed upon them.

25 A screw, *d*, screwed into and up through the plate B and against the lower surface of one of the rails R, serves to confine the bed A in position on the rails, upon which, when not clamped to them, the bed may be slid longitudinally of them, either toward or away from the lathe-arbor.

30 In its upper part the bed has made through it a dovetailed groove, *e*, to receive and guide rectilinearly a correspondingly-formed slide, C, furnished with a cylindrical neck, *f*, which extends up from it in manner as represented. The bed A is provided with an adjusting-screw, D, adapted to it and the slide C and for effecting lengthwise movements of the slide

40 in the groove *e*. There encompasses and is fitted to revolve on the neck *f* a cylindrical cap, E, which I term the "monitor," it having properly adapted to it and the slide C a screw, *g*, for effecting vertical adjustment or movement of it, the said cap, on the said neck, the screw being so applied to the cap as to admit of the latter being revolved on the neck.

50 From the above it will be seen that the cap or monitor E is susceptible not only of vertical but of rotary movements on the neck.

In order to prevent the cap while being moved vertically from revolving on the neck, such cap is provided with a vertical groove, *h*, to receive the inner end of a screw, *i*, screwed into and through a standard, *k*, erected on the slide C.

The cap or monitor E serves as a pivot to support a rotary platform, F, furnished with a cylindrical tubular neck, *i'*, to encompass and fit to the said cap, such neck being provided with a set-screw, *h'*, arranged, as represented, to screw into it, and a setting-hole, *l*, made in the cap.

65 The platform F is grooved lengthwise to receive and guide rectilinearly a slide-plate, G, provided with an abutment, *m*, and set-screws *n n*, for supporting the piece of work to be operated on by a tool carried by the lathe-arbor, or a chuck suitably adapted thereto; or, instead of the plate G, the platform F may be without the groove, and may have applied directly to it the abutment and screws. Besides a rotary motion horizontally of the platform on the cap, the latter and its adjusting-screw admit of the platform being moved vertically to various altitudes relatively to the arbor of the lathe, such being occasionally necessary, in order to bring a piece of work to be bored or drilled to or into the requisite position for being acted on by the drill or tool of the arbor. Furthermore, the platform, by appliances below it, can be adjusted transversely as well as longitudinally of the bed-rails, from all of which it will be seen that my said explained slide-rest is one of great practical value and utility.

I claim—

75 The slide-rest substantially as described, composed of the rotary platform F, cylindrical and vertically-grooved cap or monitor E, vertically-adjusting screw *g*, cylindrical neck *f*, guide-screw *i*, standard *k*, slide C, adjusting-screw D, and supporting grooved bed A, all arranged and adapted essentially in manner and to operate as set forth, and having appliances for clamping the bed to the frame of a lathe, as occasion may require.

LLEWELLYN LANDERKIN.

Witnesses:

R. H. EDDY,
E. B. PRATT.